

## Driving Sustainability: Synergy between Electric Vehicles and Building Energy Systems to Create an Interconnected Energy Ecosystem

Md Shameem Ahsan<sup>1</sup>, Md Shakhawat Hossain<sup>2</sup>, Saeed Hasan Nabil<sup>3</sup>, Md Jakaria Talukder<sup>4</sup>

<sup>1</sup>Department of Industrial & System Engineering, Lamar University, USA

<sup>2,3,4</sup> Department of Electrical & Computer Engineering, Lamar University, USA

**Corresponding Author:** Md Shameem Ahsan, [shameem6123@gmail.com](mailto:shameem6123@gmail.com)

---

### ARTICLE INFO

*Keywords:* Sustainability, Electric Vehicles, Building Energy System, Energy Management, Energy Ecosystem

*Received :* 20, September

*Revised :* 27, September

*Accepted:* 29, September

©2023 Ahsan, Hossain, Nabil, Talukder: This is an open-access article distributed under the terms of the [Creative Commons Attribution 4.0 International](https://creativecommons.org/licenses/by/4.0/).



### ABSTRACT

This article explores the symbiotic relationship between electric vehicles (EVs) and building energy systems, aiming to establish an interconnected energy ecosystem for sustainable development. As renewable energy sources and technological innovations continue to advance, EVs emerge as a key strategy for decarbonizing transportation. By integrating EVs with building energy systems, numerous benefits can be realized, including reduced carbon emissions, enhanced energy efficiency, and optimized utilization of renewable energy. This synergy transforms the traditional approach to energy consumption, offering both environmental and economic advantages. Through an analysis of industry research, this study identifies three key concepts: sustainable energy ecosystems, building energy systems, and EV charging infrastructure. By leveraging this synergy, society can drive towards a more sustainable and interconnected energy future.

---

## **INTRODUCTION**

In recent years, the world has witnessed an undeniable environmental awareness. With time, the consequences of climate change become more apparent. Governments, companies, and individuals investigate sustainable solutions to decrease their carbon footprint. Fuel-efficient technologies replacement improved the overall purity of the air, but climate change issues persist. The research (Cao et al., 2021) claims that 24% of greenhouse gas emissions originated from the automobile sector, which includes 72% from ground transport. Stakeholders require more participation and effort to transition to green transportation. One such solution that promotes the sustainable development of building energy systems is the introduction of electric vehicles. This study first examines how the emergence of renewable energy sources can increase the stability of electricity markets. Consider how adopting electricity distribution can contribute to an eco-friendly and more sustainable future.

## **LITERATURE REVIEW**

Among all the challenges for cities, the management of sustainable and safe transportation is in the quest to reduce greenhouse gas emissions dramatically. According to a report, the United Kingdom's road transportation is the prominent contributor to greenhouse gas emissions, accounting for 24% of all emissions in 2020. Sustainable transport is quickly becoming a popular environmental trend in companies, and switching to an electric automobile is becoming increasingly attractive for environmentally conscious drivers.

The environmental influence of electric vehicles is lesser than that of conventional gasoline or diesel vehicles. EVs produce no exhaust emissions from harmful agents and gain power from renewable energy sources. Many people are also interested in the sustainability of the electric vehicle manufacturing process. Overall, EVs provide a practical and environmentally friendly alternative to traditional fossil fuel vehicles and represent an optimistic step towards a more sustainable future. One of the major solutions is the adoption of EVs to achieve more eco-friendly transportation. Further, we will explore the importance of electric vehicles and the essential role of an energy-efficient transportation system in building a sustainable mobility future.

## **ELECTRIC VEHICLES**

Many experts have studied greenhouse gas emissions from the transport sector and how they affect the environment in great detail. As a result of excessive fuel usage, there are high emissions from the transportation sector and other unsettling affecting variables. (Kinnear et al., 2015; Wu et al., 2015; Geng et al., 2013; Kasman & Duman, 2015; Oladunni et al., 2022). Sustainable manufacturing aims to provide the commodities people need for daily living while minimizing environmental harm, safeguarding natural resources, and promoting social and economic well-being. It includes implementing strategies to reduce waste, ensure safe working conditions, decrease energy consumption,

promote environmentally friendly design, and balance environmental, social and economic factors to create products that do not harm the planet. It may include implementing a circular economic approach, where materials used in production are brought into work to reduce waste and promote ethical working practices throughout the supply chain. It could also enclose the production processes of renewable energy sources to minimize waste and energy consumption. It consumes recycled or environmentally friendly materials in products.

As a result of their zero-emission nature and advancements in battery technology, electric automobiles have achieved tremendous popularity in recent years. The global electric vehicle market is detecting exceptional growth, with an estimated compound yearly growth rate of 29.4% from 2020 to 2027. Sustainable transportation emphasizes automobile engineers' focus on the advances in charging infrastructure, battery technology, and government initiatives. Companies can add electric vehicles to their fleet or provide electric charging stations for employees and customers. Many researchers mentioned that the transportation industry has an extreme reduction in GHG (greenhouse gas) discharges due to the decreased reliance on petroleum and gas by integrating EVs (Marshall et al., 2013; Rahman et al., 2016).

#### **TYPES OF ELECTRIC VEHICLES**

All electric vehicles consist of the following three parts:

- Controllers.
- One or more electric motors.
- Charging system with a battery for storing electrical energy.

Contrary to combustion systems of engines, electric vehicles use batteries to provide energy for travel, allowing users to move without using fuel or polluting the environment. In addition, the standard household power grid or a charging station supplies the electricity required to charge the batteries (Khaligh & Li, 2010). Various technologies increase the efficiency of electric vehicles, such as braking energy recovery. There are currently different passenger cars on the market that use a battery-powered electric traction motor that is: HEVs, PHEVs, and EVs or BEVs (Phev & Charger, 2013).

Researchers (Rajabinezhad et al., 2022; Jayasinghe et al., 2017; Taghizad-Tavana et al., 2023) categorize All EVs (AEVs) into three classes.

#### **EXTENDED-RANGE ELECTRIC VEHICLE (ER-EV)**

An ER-EV consists of an electric drive system (one or more electric motors and a battery) and an inner combustion engine to charge the battery. ER electric vehicles help overcome range anxiety, reduce fuel costs, are highly efficient, and maximize utilization through continuous engine operation. The electric motor of ER-EV only powers the range extender, and the combustion engine solely charges the electric vehicle's battery. Therefore, ER electric vehicles may disconnect from the power grid and refuel at a gas station. (Taghizad-Tavana et al., 2023)

## BATTERY ELECTRIC VEHICLE (BEV)

BEVs have a higher priority when charging at charging posts because they only have a single battery (Acharige et al., 2022). The EPA (Environmental Protection Agency) calls BEVs zero-emission electric vehicles because they produce no direct or indirect emissions (Taghizad-Tavana et al., 2023).

## FUEL CELL ELECTRIC VEHICLE (FCEV)

FCEVs do not emit greenhouse gases and are more practical than the internal combustion of a vehicle's engine. The energy source for fuel cell electric vehicles is hydrogen, which only produces steam and hot air. The installation of FCEVs and the hydrogen infrastructure required to power them is still in its early stages.

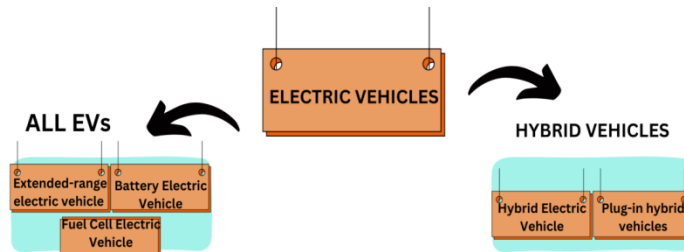

Figure 1: Categories of Electric Vehicles

The researchers in the paper (Taghizad-Tavana et al., 2023) mentioned that "the United States Department of Energy is a leader in the development of affordable, safe, and environmentally friendly hydrogen cars. The Energy Policy Act of 1992 classifies hydrogen as an alternative fuel, making it eligible for tax credits for alternative fuel vehicles."

## METHODOLOGY

The objective of this literature review is to provide a thorough examination of the utilization of smart charging techniques of electric vehicle throughout the various phases of the energy management system. The review aims to identify the predominant integration techniques employed to address the challenges at each phase and determine their possible solution. Additionally, it seeks to explore how the application of smart integration at different stages enhances the collaboration of charging facility led to energy ecosystem. Each publication included in this review has been meticulously analyzed and compiled to offer a comprehensive overview of the current state of the art and its potential for future advancements.

## OPTIMAL INTEGRATION OF V2H AND V2B TECHNOLOGIES

Vehicle-to-home (V2H) and vehicle-to-building (V2B) are more practical near-term alternatives to vehicle-to-grid (V2G). These alternatives enable plug-in electric vehicles (PEV) to export power from their battery into a building V2H, or V2B, is commonly used within a building microgrid in coordination with stationary battery energy storage systems. The consumption of V2H or V2B with the help of behind-the-meter energy management in buildings improves the self-consumption of on-site distributed generation units. It also results in increasing the grid's reliability (He et al., 2022).

PEVs can serve as loads during charging intervals, also known as the Grid-to-Vehicle (G2V) mode of operation. As prospective sources of energy at other times, also known as the Vehicle-to-Grid (V2G) mode of operation. PEVs can compensate for reactive power and increase the grid's capabilities and stability (Amin Kazemi et al., 2017). In PEV charging, cost and energy losses are competitive objective functions (Esmaili & Goldoust, 2015). Many studies have researched professional charging strategies for plug-in hybrid electric automobiles (PHEVs) to increase the use of renewable power resources and decrease dependence on the central grid.

### **CHARGING METHODS IN RESIDENTIAL BUILDINGS**

There are abundant PV-battery procedures applied in residential buildings currently in the market. PV modules, power inverters, a battery storage device, and a control component combine to compose a PV battery system. The battery connects to the AC- or DC-side of the PV inverter. In residential energy systems, multiple investigations have studied different PHEV charging methods, such as

- Combine PV and EV capacity inspection for distribution grids.
- Demand response capability of PHEVs when paired with high penetration of PVs.
- Vehicle-to-grid scheduling of multiple EVs considering time-of-use electricity tariffs. (He et al., 2022)
- Load-shaping algorithms for demand response purposes, considering EVs.
- Optimally integrates the solar and batteries into nano-grids with PHEVs.

### **DEMAND-SIDE MANAGEMENT**

Demand-side management (DSM) has been committed to achieving greater demand-side flexibility and thus facilitating the integration of renewable energy resources (RERs) in the residential distribution network. (He et al., 2022)

### **DISTRIBUTION NETWORK**

In residential, commercial, and industrial regions, the distribution networks (DN) oversee supplying electricity to each linked electric load. (Ahmad et al., 2022). Allowing EVs to charge and discharge without control may cause voltage changes in the grid (Singh et al., 2013). However, if EVs can charged/discharged intelligently, they can operate as distributed energy sources and level the distribution network's load profile by offering peak shaving and valley filling (Singh et al., 2013).

DSM control techniques have considered many controllable load resources (CLRs), such as:

- EV charging.
- Heating, ventilation, and air conditioning (HVAC) systems

- Controllable home appliances.

## **CHARGING METHODS IN COMMERCIAL BUILDINGS**

For commercial buildings, a workplace charging program paired with on-site solar energy systems could be more efficient in enhancing self-consumption and maximizing the potential benefits of EVs.



Figure 2: Charging station in Commercial building.

Several studies have explored the possibilities for commercial building micro-grids, such as:

- Optimize two-way communication energy management systems for grid-connected smart buildings in universities.
- Design two-stage hierarchical algorithms to decrease electricity costs and reduce power fluctuations in office buildings.

## **IMPACT OF ELECTRIC VEHICLE PRODUCTION**

It is significant to consider the environmental impact of electric vehicle production. Electric vehicles significantly reduce CO<sub>2</sub> emissions compared to gasoline or diesel vehicles. Building an electric vehicle requires lithium-ion batteries, which affect the environment. The advances and increased production volumes have decreased energy usage and emissions in battery manufacturing. However, many manufacturers are taking steps to combat the environmental impact. Tesla has installed a large photovoltaic panel in its Giga-factory that generates enough energy to power the building. Electric vehicle batteries have a long lifespan; current estimation shows they last every 10 to 20 years. The interior of an electric vehicle is also often made of recycled or sustainable materials.

## **DECREASING GREENHOUSE GAS EMISSIONS**

Electric automobiles have great potential to reduce greenhouse gas (GHG) emissions. Integrating electric vehicles into building energy systems is a primary solution in the fight against air pollution. Electric automobiles emit no exhaust fumes. We can further reduce carbon emissions by ensuring these vehicles charge with renewable energy.

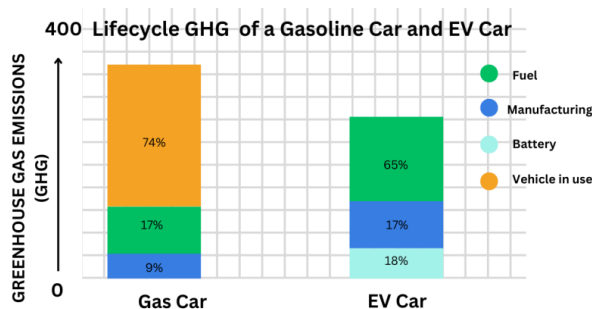

Figure 3: Graphical representation of GHG Emissions of a Gasoline and EV car

## ENERGY EFFICIENCY

Electric vehicles are more energy efficient than vehicles with internal combustion engines because they use more energy stored in batteries. Once connected to the grid, EVs can store excess electricity during off-peak times and feed it back into the building's energy system when demand is high. This bidirectional power flow ensures efficient use and relieves the load on the grid during peak times. EVs restore around 59–62% of the electrical power from the grid to energy at the wheels, whereas gasoline-powered cars only convert about 17–21% of the energy stored in fuel.

## LOWER RUNNING COSTS

As a result of the rising fuel use per person, fuel costs are rising daily. Many studies have taken place over the last 20 years on biofuel usage for internal combustion engines (Tsaousis et al., 2014; Al-lwayzy & Yusaf, 2017; Subramaniam et al., 2020). Compared to gasoline vehicles, electric vehicles have lower fuel and maintenance costs. It has a beneficial impact on the finances of the owner. Investing in EVs for building energy systems can lead to long-term savings. Additionally, using electric vehicle batteries for energy storage can reduce peak electricity costs, resulting in significant savings for building owners.

## DEMAND RESPONSE

EVs can partake in demand response schedules where they get charged or discharged based on the electric grid requirements. By intelligently controlling electric vehicle charging, building operators can reduce costs by avoiding electricity price spikes and promoting grid stability during high demand. Electric cars have become increasingly popular as environmentally friendly transportation in recent years. Electric transport uses battery-powered electric motors, eliminating the need for fossil fuels. As demand for eco-friendly transportation increases, the electric vehicle industry continues to innovate and provide a possible alternative to traditional internal combustion engine vehicles.

## THE FUNCTION OF EV AGGREGATORS IN SMART CHARGING

Aggregators are new energy systems that act as interfaces between power systems and consumers, influencing various units connected to the grid. They play a significant role in optimizing energy programs and energy system

control services. Moreover, it is essential to remember that electric cars (EVs) are portable storage devices that may be charged or discharged via distribution networks (Pirouzi et al., 2022). As a result, an EV has a battery that offers flexibility. The EVs in the parking lot (EVPL) parking lot/aggregator thus qualify as a flexible resource with an acceptable response time (Pirouzi et al., 2022). It is due to the inherent fast dynamics that collaborate with the quick control possibility based on power electronic converters (Phev & Charger, 2013).

Aggregation is the act of uniting multiple entities in a power system (e.g., consumers, producers, prosumers, or any combination thereof) to act as a single entity while engaging in power system markets (both wholesale and retail) or providing services to the system operator(s) (Burger & Pablo Chaves-Ávila, 2017).

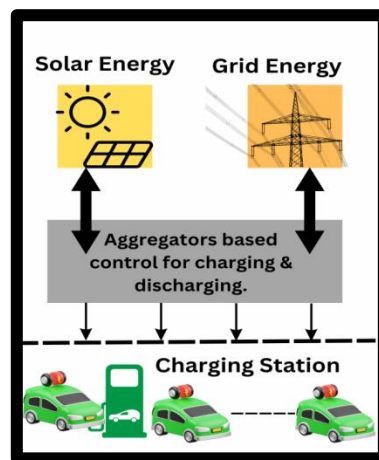

Figure 4: Coordination framework of EVs with aggregators

## TYPES OF AGGREGATORS

Aggregators can be of various categories, e.g.

- Demand response aggregators.
- Retail aggregators.
- Electric vehicle aggregators.

## PURPOSE OF EV AGGREGATORS

The goal of EV aggregators is to support the V2G mechanism by collecting electric vehicles as distributed energy sources and managing battery state-of-charge estimates. They supply electricity and control the charging and discharging of electric vehicles in certain partner areas. Aggregators generate the signals needed to coordinate a fleet of electric vehicles based on data exchanged between energy market suppliers, transmission system operators, and distribution system operators.

## SMART CHARGING OF EV's FOR BUILDING ENERGY SYSTEMS

Electric vehicles (EVs) are decarbonizing and altering the automobile market (Gandini, 2022). Shortly, millions of new electric automobiles will be on the roads, and this trend will accelerate rapidly in the coming years. To maximize the benefits of this change for both consumers and the environment,

it is also essential that we accelerate the global implementation of an efficient EV charging infrastructure.

By 2040, the industry expects 300 to 500 million electric vehicles to be installed. Getting the charging infrastructure right for EVs will be significant in building an efficient decentralized energy system for sustainable development (Gandini, 2022).

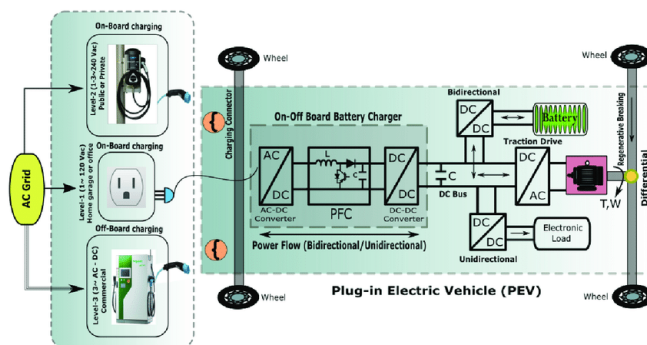

Figure 5: Charging process of Electric Vehicle in Charging Infrastructure (Habib et al., 2018)

Most of the current policies concentrate on the placement of public charging infrastructure. Around 90% of EV chargers installed by 2040 will be in private locations, primarily residential, commercial, and industrial buildings (Gandini, 2022). Therefore, it is essential to evaluate what potential added value the implementation of intelligent and private EV charging technology in buildings has for EV drivers, system operators, and other stakeholders.

## SUSTAINABILITY OF EV CHARGER AND BATTERY

Charger and battery sustainability depend on factors such as:

- Materials used.
- The manufacturing processes.
- End-of-life disposal.

While EV engineers and designers can always do more to improve responsible mining and recycling, battery manufacturing and technology techniques are becoming more eco-friendly over time. When an EV battery is not functioning in the electric vehicle anymore, it will work for home or business purposes, so it does not require it to come to the end of its life. The time the battery consumes in your automobile is only the start, as engineers are already discovering innovative ways to use them.

## ADVANTAGES OF SMART CHARGING (EV'S) IN BUILDING

According to the findings (Gandini, 2022), the benefits of this approach are surprising to both consumers and system operators.

The results of the paper highlight that:

- On average, smart EV charging stations installed in buildings are more accessible to consumers than equivalent public charging points.
- Estimation shows that sufficient smart charging of electric vehicles could generate savings for consumers compared to the costs of public EV

charging, especially if combined with time-of-use tariffs and demand surcharges.

Utilizing cargo management systems further improves the savings. (Gandini, 2022)

- By integrating smart charging technology into buildings, local and global networks become more resilient. The requirement for significant and expensive accompanying infrastructure expenditures is another issue that cargo management systems assist with.
- Lastly, the average reduction in CO2 emissions associated with smart EV charging in buildings is more significant than public or uncontrolled charging at the building level.

## EV CHARGING INFRASTRUCTURE

The charging infrastructure enterprise has embraced a standard norm known as the Open Charge Point Interface protocol. With the following elements of charging stations: location, EV charging port, and connector. The Alternative Fuels Data Center and Station Locator use the following charging infrastructure definitions:

- **Electric Vehicle Charging Port:** The electric vehicle charging port provides the power required to charge a single automobile, although it can have multiple ports. The unit containing the electric vehicle charging ports is also known as a charging station and may have one or more EV charging ports. EVSE (Electric Vehicle Electrical Equipment) ports are electric vehicle charging ports.
- **Station Location:** A site with one or more electric automobile charging ports at the same address refers to a station location. Examples of this are garages or parking lots in shopping centers.

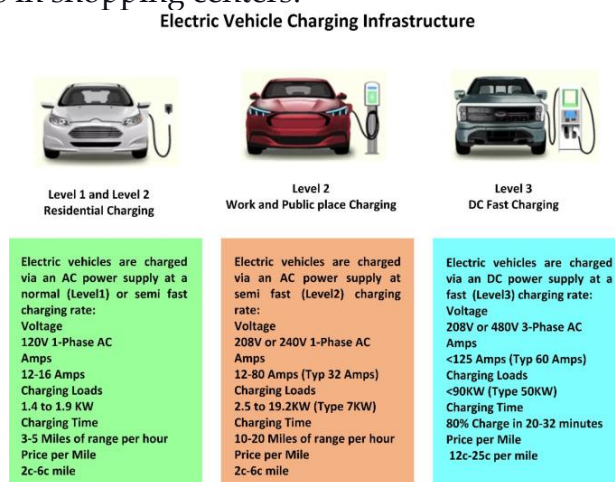

Figure 6: Overview of charging infrastructure for electric vehicles (Mastoi et al., 2022)

- Plug: The plug connects to the electric vehicle for charging. Multiple ports and plug types (e.g., CHAdeMO and CCS) may be available in a single EV charging port. But only charge one vehicle at a time. The plugs and connectors refer to the same object. Chargers for electric transport are rated based on the charging speed of the batteries.

An electric vehicle charging station can have multiple EV charging ports, and each electric vehicle charging port can have one or more ports.

## CONTROL INFRASTRUCTURE FOR EV CHARGING

The main goal is to optimize the performance and efficiency of charging EVs based on advanced control and communication systems.

EV charging controls include the following:

- EVs.
- Power grid.
- EV charging stations.

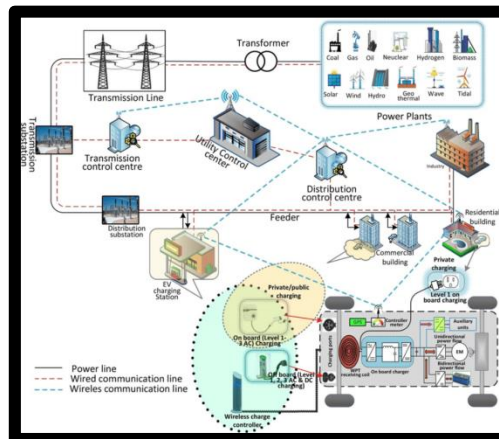

Figure 7: Schematic diagram of EV charging infrastructure (Kumar & Ravi, 2022).

## COMMUNICATION INFRASTRUCTURE

Communication infrastructure is essential in recognizing the real-time monitoring and control management of EV charging (Ahmed & Kim, 2017).

A communication network has three classes:

- Application level.
- Communication network level.
- Device level.
- **COORDINATION CONTROL FOR CHARGING EV'S**

## UNCOORDINATED CONTROL

Uncoordinated charging occurs when the charging cycle is at peak consumption, power losses are high, distribution transformers are overloaded, and the network's reliability is low (Taghizad-Tavana et al., 2023). Smart chargers can help reduce peak load time and optimize energy consumption.

## COORDINATED CONTROL

Coordinated charging occurs when the charging operation of EVs is not at peak load. Also, the network load is at its lowest (Hajforoosh et al., 2012). EV users select the fixed and dynamic charging infrastructure, considering the mobility of EVs. A distribution network divides Electric vehicle charging stations. Centralized and decentralized charging methods can control the power distribution of EV charging stations (Taghizad-Tavana et al., 2023).

- Centralized charging is limited according to the size of the optimization problem and increases with the number of EVs in an area.
- Decentralized control ensures an optimal charging process for EV owners when deciding on the charging patterns.

## RESEARCH RESULT

### SYNERGY BETWEEN BUILDING ENERGY SYSTEM & EV'S

A unique synergy emerges when building energy systems and electric vehicles work together, creating a sustainable ecosystem.

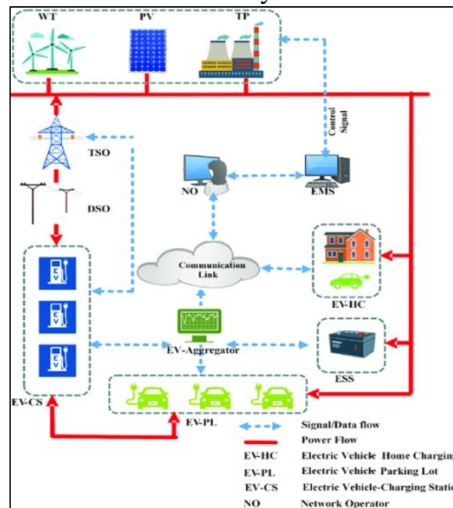

Figure 8: The typical structure of synergy between electric vehicles and building energy management systems (Rathor & Saxena, 2020).

Significant progress has appeared in recent years at the intersection of electric vehicles (EVs) and buildings. In 2019, more than 7.2 million electric vehicles were on the roads worldwide, a 40% increase from the previous year. This exponential growth will continue. Estimates suggest that the number of electric automobiles worldwide could reach 125 million by 2030. By connecting the charging of electric transport to the building energy systems, intelligent integration enables dynamic load balancing and thus optimizes energy consumption throughout the day. Charging electric vehicles during off-peak times, when electricity demand is low, can help reduce strain on the grid and minimize electricity costs.

According to Italy's proposed National Energy and Climate Plan, the national power system's flexibility in 2030 will primarily come by increasing electricity storage capacity and smart charging of electric vehicles (Fattori &

Tagliabue, 2019). Creating a symbiotic relationship between electric vehicles and buildings is a significant step to moving the world towards a more sustainable future. By focusing on efficient energy management and the consumption of innovative technologies, we can build a greener and more sustainable world for upcoming generations.

Buildings play a significant role in supporting the development and success of electric vehicles through:

- Infrastructure development.
- Smart energy integration.
- Vehicle-to-grid (V2G) technology.

## **DEVELOPMENT OF INFRASTRUCTURE**

The infrastructure's development permits electric vehicle owners to charge their vehicles effortlessly. It results in boosting their day-to-day driving limitations.

## **SMART ENERGY INTEGRATION & SUSTAINABLE ECOSYSTEM**

Smart or intelligent energy integration allows prioritizing charging processes during off-peak times when the power requirements and energy costs are generally lower and cheaper. This intelligent energy management reduces grid load, minimizes peak demand, and maximizes the use of renewable energy, contributing to a more sustainable energy ecosystem. The effective integration of electric vehicles and building energy systems offers numerous benefits that contribute to a greener and more efficient future. By connecting the charging of electric transport to the building energy systems, intelligent integration enables dynamic load balancing and thus optimizes energy consumption throughout the day. Charging electric vehicles during off-peak times, when electricity demand is low, can help reduce strain on the grid and minimize electricity costs.

## **VEHICLE-TO-GRID (V2G) TECHNOLOGY**

A V2G algorithm originates to schedule energy and ancillary services more efficiently (Sortomme & A. El-Sharkawi, 2011). With V2G technology, electric vehicles not only consume energy from the grid. But also feed excess energy reverse into the building or a larger power grid. This bidirectional energy flow can provide numerous benefits, including grid stabilization, energy cost optimization, backup power, financial incentives, and revenue generation for electric vehicle owners. As (Kiviluoma & Meibom, 2011) have calculated the advantages derived using the V2G and different supplementary services. V2G could boost the benefits of smart EVs by allowing them to discharge their batteries to the power grid when it is cost-effective. (Kiviluoma & Meibom, 2011).

## **INITIATIVE: ENERGY FOR SUSTAINABILITY (EFS)**

In 2006, a group of professors at the University of Coimbra agreed to establish a multidisciplinary initiative called Energy for Sustainability (EFS)

(Soares et al., 2018). Its origins trace back to past cooperation involving the co-supervision of Ph.D. and MSc theses. These professors discovered they shared many scientific interests and had a substantial potential to carry out new research initiatives, industry contracts, and postgraduate programs (Soares et al., 2018).

Electric vehicles can work as mobile energy storage devices with high-performance batteries. The balanced integration of these technologies can have far-reaching benefits and applications.

- **Grid Stability and Reliability:** Electric cars are efficient smart grid devices as they can provide lower fuel usage and CO<sub>2</sub> emissions (Painuli et al., 2019). Electric vehicle integration helps stabilize the power grid by regulating voltage fluctuations and absorbing excess power during peak hours. This flexibility helps improve grid reliability, particularly in regions with high renewable energy penetration.
- **Energy interaction:** By connecting electric vehicles to the building's energy grid, excess power to charge electric transport reduces the strain on external power grids. Buildings can decrease their dependence on the grid during peak demand periods by leveraging the power of electric vehicle batteries, thereby avoiding costly power losses.
- **Smart charging:** By intelligent charging systems, electric vehicles can recharge during off-peak hours when a significant renewable energy source is available. This approach optimizes energy distribution and minimizes stress on the power grid. Charging electric vehicles also encourages the using renewable energy sources (Amjad et al., 2018).
- **Enhanced environmental impact:** When electric vehicles charge using renewable energy from buildings. It heightens the various environmental benefits. It enables better financial management and promotes the development of renewable energy sources.

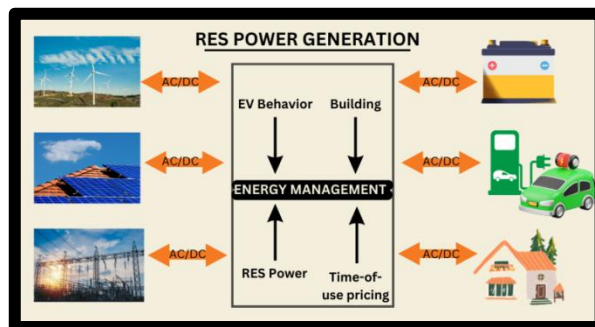

Figure 9: The Illustration of RES (renewable energy sources) power generation.

## BUILDING ENERGY FLEXIBILITY

Building energy flexibility is a term that efficiently participates in energy grid process management (Xu et al., 2022). Generally, it refers to the burden with adjustable features that can energetically partake in energy grid operation control and interact with the power grid (Xu et al., 2022). The idea of flexibility means the characteristics to maintain balance in power generation (i.e., energy

consumption) under uncertainty in the power system. The building load could be flexible through resource regulation and a dynamic power management tool. Power storage systems in load movement or adjustment play a significant role in achieving flexible electricity loads. It is variable within a specific time, so load uncertainty should be especially assumed since it has a noticeable impact on the outcomes (Xu et al., 2022).

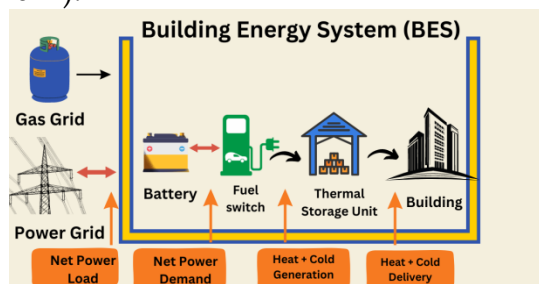

Figure 10: Different flexibility and energy storage options within a building.

Relying on the states of energy usage, battery-based energy storage, and thermal electricity storage are essential for battery energy storage systems (BESS) (Xu et al., 2022).

As for battery-based energy storage, the maintenance effect of battery storage on building energy consumption and the maintenance capacity of battery storage on the power grid all show significant impacts. For thermal energy storage, it is a novel concept to use building systems and furniture for heat storage (Xu et al., 2022). Local energy systems, such as energy storage units, wind farms, distributed energy resources, and solar photovoltaic (PV) systems, have become increasingly important in the power market (Valipour et al., 2022; Lingcheng et al., 2019).

## MODES OF BATTERY SYSTEM

Specific modes are the PV-battery system, the wind-battery system, and the PV-wind-battery systems.

### PV-battery system

The variety of batteries and PV systems expands the usage of solar radiation and the on-site self-supply of infrastructure.

### Wind-battery system

Contrary to the PV system, the wind system has increased application needs. For the wind-battery system, the electricity produced by the wind changes with weather situations. On a preset day, the energy contribution of wind to the grid can vary incredibly. It is encouraged to deploy small wind turbines (SWTs) in urban areas to reduce carbon emissions and to avoid costly modifications that come with a high penetration rate of fast charging stations (FCSs) (Amer et al., 2021).

### PV-wind-battery systems

A hybrid PV-wind system (HPWS) may weaken the problem caused by the prominent uncertainty and intermittence of renewable energy sources. This

uncertainty may result in unreliability in building load demand by only using one source.

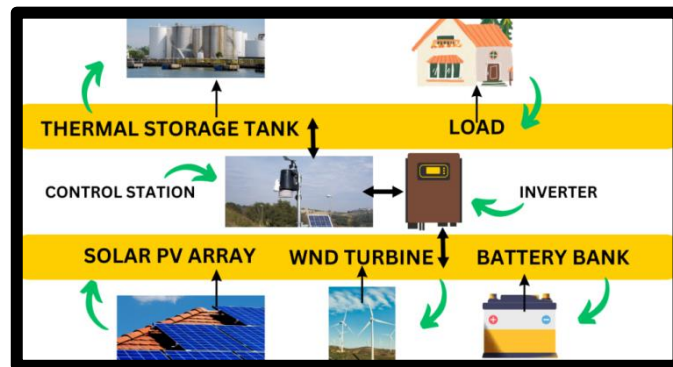

Figure 11: The PV wind battery storage system

### OBSTACLES TO THE INTEGRATION OF EV'S

The sustainable development of developed cities gets support from electric vehicles, as emphasized by countries where electric automobiles are supported and exempt from vehicle tax. However, the prominent obstacles discussed above continue to hinder the full integration of electric vehicles into smart cities. The price of electric vehicles, including the purchasing and charging costs, is a significant factor in their adoption. The price difference between the initial purchase price of an electric automobile and an internal combustion engine vehicle remains crucial.

Similarly, the initial funds required to purchase an electric vehicle are high. Therefore, the integration of EVs faces technological, economic, and social challenges. Ranging from infrastructure requirements to user concerns about the price of electric vehicles, charging times, the lack of electric automobile charging stations, safety, reliability, range, and availability of electric transport. The maintenance services of EVs range in battery life. However, EVs' limited driving range and insufficient charging stations have hampered their wider acceptance. Building several charging stations is essential to encouraging private car drivers to switch to electric vehicles. (Yang et al., 2018)

With the rise in electric vehicle adoption, there's a growing concern about their impact on the electricity grid, including heightened losses, load spikes, and voltage irregularities. This necessitates enhanced grid management to handle increased demand effectively. In smart city environments, energy systems are particularly vulnerable to security breaches and cyber threats due to their reliance on real-time data collection for setting energy prices and meeting demand. Addressing data security and privacy concerns is crucial in tackling these challenges.

### CONCLUSIONS AND RECOMMENDATIONS

Suggestions for the Integration of Electric Vehicles in Smart Cities address technological, financial, and social issues related to infrastructure restrictions, legal frameworks, and creative business models that can be compatible with future technological innovations. The compatibility and standardization of electric vehicle infrastructure and technologies will be

significant factors. That will have a positive impact on the integration of electric vehicles into developed cities to drive sustainability. Integrated energy systems (IES) must be unified and operated to satisfy several demands due to environmental concerns like the climate change crisis and improving sustainability and energy efficiency (Kasra Saberi-Beglar et al., 2023).

The standardization of the EV is effective for the mobility sector. It also affects the way of electricity production, storage, and distribution in a smart grid using V2G technology. The ongoing burning of fossil fuels in engines has resulted in the emission of greenhouse gases (GHGs). According to verified sources, that is causing global warming to worsen (Ogunkunle & Ahmed., 2019; Lim & Teong., 2010). Concerns about climate change, energy security, urban air pollution, and rising demand for transportation services are driving the adoption of renewable energy-powered automobiles (Melaina & Bremson, 2008).

In conclusion, digital innovations are considered vital tools to help achieve various SDGs' social, economic, and environmental sustainability objectives and steer the world towards the envisaged 2030 Agenda. Electric vehicles are perhaps one of the most exciting innovations in recent times that can help reduce pollution-causing emissions. The optimal integration of electric vehicles and building energy management systems holds immense potential to revolutionize the means of EVs' consumption, storage, and management of energy. This harmonious link contributes to a more sustainable and eco-friendly future. It also enhances grid stability, energy efficiency, and financial savings. As we embrace the power of intelligent integration, the synergy between EVs and building energy systems will lead us toward a cleaner, greener, and more sustainable world. This article provided trendy knowledge on several topics in energy systems toward a more sustainable and energy-efficient future.

#### **ADVANCED RESEARCH**

The researcher knows that there are still many errors in language, writing and presentation style when writing this article, taking into account the limitations of the researcher's own knowledge and abilities. Therefore, researchers received in-depth input and suggestions from various sources.

## REFERENCES

- Acharige, S. S. G., Haque, M. E., Arif, M. T., & Hosseinzadeh, N. (2022). Review of Electric Vehicle Charging Technologies, Configurations, and Architectures. *ArXiv:2209.15242 [Cs, Eess]*.
- Ahmad, M., & Rahman, M. M. (2022). Augmented Kalina Cycle Using Renewable Energy as Input for Power Generation. *International Journal of Chemical Engineering and Applications*, 13(2)
- Ahmad, F., Iqbal, A., Ashraf, I., Marzband, M., & Khan, I. (2022). Optimal location of electric vehicle charging station and its impact on distribution network: A review. *Energy Reports*, 8, 2314–2333.
- Ahmed, M. H., & Kim, Y.-C. (2017). Performance Analysis of Communication Networks for EV Charging Stations in Residential Grid. *Proceedings of the 6th ACM Symposium on Development and Analysis of Intelligent Vehicular Networks and Applications*.
- Ahmed, M. (2023). Harvesting Green Power: A Literature Exploration of the Augmented Kalina Cycle with Renewable Energy Sources. *Global Mainstream Journal of Innovation, Engineering & Emerging Technology*, 2(01), 01-14.
- Al-lwayzy, S. H., & Yusaf, T. (2017). Diesel engine performance and exhaust gas emissions using Microalgae *Chlorella protothecoides* biodiesel. *Renewable Energy*, 101, 690–701.
- Amer, A., Azzouz, M., & Azab, A. (2021). A Stochastic Program for Siting and Sizing Fast Charging Stations and Small Wind Turbines in Urban Areas | *IEEE Journals & Magazine* |
- Amin Kazemi, M., Rasouli, M., & Sabzehgar, R. (2017). An optimized scheduling strategy for plugged-in electric vehicles integrated into a residential smart microgrid for both grid-tied and islanded modes
- Amjad, M., Ahmad, A., Rehmani, M. H., & Umer, T. (2018). A review of EVs charging: From the perspective of energy optimization, optimization approaches, and charging techniques. *Transportation Research Part D: Transport and Environment*, 62, 386–417.
- Burger, S., & Pablo Chaves-Ávila, J. (2017). A review of the value of aggregators in electricity systems. *Renewable and Sustainable Energy Reviews*, 77, 395–405.
- Cao, J., Chen, X., Qiu, R., & Hou, S. (2021). Electric vehicle industry sustainable development with a stakeholder engagement system. *Technology in Society*, 67(1), 101771. *Sciedirect*.
- Esmaili, M., & Goldoust, A. (2015). Multi-objective optimal charging of plug-in electric vehicles in unbalanced distribution networks. *International Journal of Electrical Power & Energy Systems*, 73, 644–652.

- Fattori, F., & Tagliabue, L. (2019). Enhancing Power System Flexibility Through District Heating - Potential Role in the Italian Decarbonisation | IEEE Conference Publication |
- Gandini, L. (2022). Carga inteligente de vehículos eléctricos en los edificios. Bienvenido al Blog de Schneider Electric.
- Geng, Y., Ma, Z., Xue, B., Ren, W., Liu, Z., & Fujita, T. (2013). Co-benefit evaluation for urban public transportation sector - a case of Shenyang, China. *Journal of Cleaner Production*, 58, 82-91.
- Habib, S., Mansoor Khan, M., Abbas, F., & Sang, L. (2018). A Comprehensive Study of Implemented International Standards, Technical Challenges, Impacts and Prospects for Electric Vehicles | IEEE Journals & Magazine | IEEE Xplore. [ieeexplore.ieee.org](http://ieeexplore.ieee.org).
- Hajforoosh, S., A.S. Masoum, M., & Moses, P. S. (2012). Distribution transformer stress in smart grid with coordinated charging of Plug-In Electric Vehicles | IEEE Conference Publication |
- He, Z., Khazaei, J., & Freihaut, J. D. (2022). Optimal integration of Vehicle to Building (V2B) and Building to Vehicle (B2V) technologies for commercial buildings. *Sustainable Energy, Grids and Networks*, 32, 100921.
- Huang, Y., Wu, X., & Jing, J. (2022). Research on the electric vehicle heat pump air conditioning system based on R290 refrigerant. *Energy Reports*, 8, 447-455.
- Jayasinghe, S., Meegahapola, L., Fernando, N., Jin, Z., & Guerrero, J. (2017). Review of Ship Microgrids: System Architectures, Storage Technologies and Power Quality Aspects. *Inventions*, 2(1), 4.
- Kasman, A., & Duman, Y. S. (2015). CO2 emissions, economic growth, energy consumption, trade and urbanization in new EU member and candidate countries: A panel data analysis. *Economic Modelling*, 44, 97.
- Kasra Saberi-Beglar, Zare, K., Heresh Seyedi, Mousa Marzband, & Sayyad Nojavan. (2023). Risk-embedded scheduling of a CCHP integrated with electric vehicle parking lot in a residential energy hub considering flexible thermal and electrical loads. *Applied Energy*, 329, 120265-120265.
- Khaligh, A., & Li, Z. (2010). Battery, Ultracapacitor, Fuel Cell, and Hybrid Energy Storage Systems for Electric, Hybrid Electric, Fuel Cell, and Plug-In Hybrid Electric Vehicles: State of the Art. *IEEE Transactions on Vehicular Technology*, 59(6), 2806-2814.
- Kinncar, S., Rose, A., & Rolfe, J. (2014). Emissions Reporting in the Australian Road Freight Transport Sector: Is There a Better Method than the Default Option? *International Journal of Sustainable Transportation*, 9(2), 93-102.

- Kiviluoma, J., & Meibom, P. (2011). Methodology for modelling plug-in electric vehicles in the power system and cost estimates for a system with either smart or dumb electric vehicles. *Energy*, 36(3), 1758–1767.
- Kumar, L., & Ravi, N. A. (2022). Electric vehicle charging method and impact of charging and discharging on distribution system: a review. *International Journal of Electric and Hybrid Vehicles*, 14(1/2), 87.
- Lingcheng, K., ZhenNing, Z., Jiaping, X., Jing, L., & YuPing, C. (2019). Multilateral agreement contract optimization of renewable energy power grid-connecting under uncertain supply and market demand. *Computers & Industrial Engineering*, 135, 689–701.
- Lim, S., & Teong, L. K. (2010). Recent trends, opportunities and challenges of biodiesel in Malaysia: An overview. *Renewable and Sustainable Energy Reviews*, 14(3), 938–954.
- Marshall, B. M., Kelly, J. C., Lee, T.-K., Keoleian, G. A., & Filipi, Z. (2013). Environmental assessment of plug-in hybrid electric vehicles using naturalistic drive cycles and vehicle travel patterns: A Michigan case study. *Energy Policy*, 58, 358–370.
- Mastoi, M. S., Zhuang, S., Munir, H. M., Haris, M., Hassan, M., Usman, M., Bukhari, S. S. H., & Ro, J.-S. (2022). An in-depth analysis of electric vehicle charging station infrastructure, policy implications, and future trends. *Energy Reports*, 8(2352-4847), 11504–11529.
- Melaina, M., & Bremson, J. (2008). Refueling availability for alternative fuel vehicle markets: Sufficient urban station coverage. *Energy Policy*, 36(8), 3233–3241.
- Ogunkunle, O., & Ahmed, N. A. (2019). A review of global current scenario of biodiesel adoption and combustion in vehicular diesel engines. *Energy Reports*, 5, 1560–1579.
- Oladunni, O. J., Mpofo, K., & Olanrewaju, O. A. (2022). Greenhouse gas emissions and its driving forces in the transport sector of South Africa. *Energy Reports*, 8, 2052–2061.
- Painuli, S., Singh Rawat, M., & Rao Rayudu, D. (2019). A Comprehensive Review on Electric Vehicles Operation, Development and Grid Stability | IEEE Conference Publication |
- Pirouzi, A., Aghaei, J., Pirouzi, S., Vahidinasab, V., & Jordehi, A. R. (2022). Exploring potential storage-based flexibility gains of electric vehicles in smart distribution grids. *Journal of Energy Storage*.
- Phev, E., & Charger, B. (2013). Vehicle-to-grid (V2G) Reactive Power Operation Analysis of the Vehicle-to-grid (V2G) Reactive Power Operation Analysis of the.
- Rahman, I., Vasant, P. M., Singh, B. S., Abdullah-Al-Wadud, M., & Adnan, N.

- (2016). Review of recent trends in optimization techniques for plug-in hybrid, and electric vehicle charging infrastructures. *Renewable and Sustainable Energy Reviews*, 58, 1039–1047.
- Rajabinezhad, M. A., Firoozi, H., Khajeh, H., & Laaksonen, H. (2022). Electrical Energy Storage Devices for Active Buildings. *Green Energy and Technology*, 51–69.
- Rathor, S. K., & Saxena, D. (2020). Energy management system for smart grid: An overview and key issues. *International Journal of Energy Research*, 44(6).
- Singh, M., Kumar, P., & Kar, I. (2013) A Multi Charging Station for Electric Vehicles and Its Utilization for Load Management and the Grid Support | *IEEE Journals & Magazine | IEEE Xplore*.
- Soares, N., Martins, A. G., Carvalho, A. L., & Caldeira, C. (2018). The challenging paradigm of interrelated energy systems towards a more sustainable future. *Renewable and Sustainable Energy Reviews*, 95, 171–193.
- Sortomme, E., & A. El-Sharkawi, M. (2011). Optimal Scheduling of Vehicle-to-Grid Energy and Ancillary Services | *IEEE Journals* |
- Subramaniam, M., Solomon, J. M., Nadanakumar, V., Anaimuthu, S., & Sathyamurthy, R. (2020). Experimental investigation on performance, combustion and emission characteristics of DI diesel engine using algae as a biodiesel. *Energy Reports*, 6, 1382–1392.
- Taghizad-Tavana, K., Alizadeh, A., Ghanbari-Ghalehjoughi, M., & Nojavan, S. (2023). A Comprehensive Review of Electric Vehicles in Energy Systems: Integration with Renewable Energy Sources, Charging Levels, Different Types, and Standards. *Energies*, 16(2), 630.
- Tsaousis, P., Wang, Y., Roskilly, A. P., & Caldwell, G. S. (2014). Algae to Energy: Engine Performance Using Raw Algal Oil. *Energy Procedia*, 61, 656–659.
- Valipour, E., Nourollahi, R., Taghizad-Tavana, K., Nojavan, S., & Alizadeh, A. (2022). Risk Assessment of Industrial Energy Hubs and Peer-to-Peer Heat and Power Transaction in the Presence of Electric Vehicles. *Energies*, 15(23), 8920–8920.
- Wu, X., Zhang, S., Wu, Y., Li, Z., Zhou, Y., Fu, L., & Hao, J. (2015). Real-world emissions and fuel consumption of diesel buses and trucks in Macao: From on-road measurement to policy implications. *Atmospheric Environment*, 120, 393–403.
- Xu, X., Fu, Y., & Luo, Y. (2022). Building energy flexibility with battery energy storage system: a comprehensive review. *Discover Mechanical Engineering*, 1(1).
- Yang, H., He, J., Tang, T.-Q., & Huang, H.-J. (2018). An optimal charging station

location model with the consideration of electric vehicle's driving range.  
Transportation Research Part C: Emerging Technologies, 86, 641–654.