

IoT Monitoring Using ESP8266 on Solar Powered Aerator

Yosi Apriani^{1*}, M. Aidil Dwiansyah², Wiwin A Oktaviani³, Muhammad Hurairah⁴

Prodi Teknik Elektro, Universitas Muhammadiyah Palembang

Corresponding Author: Yosi Apriani yosi_apriani@um-palembang.ac.id

ARTICLE INFO

Keywords: Solar Cell, IoT, Aerator, Wifi

Received : 2 December

Revised : 17 December

Accepted: 20 January

©2023 Apriani, Dwiansyah, Oktaviani, Hurairah: This is an open-access article distributed under the terms of the [Creative Commons Atribusi 4.0 Internasional](https://creativecommons.org/licenses/by/4.0/).



ABSTRACT

Shrimp is one of the prima donnas of Indonesia's mainstay exports from the fishery sector which needs to be improved both in terms of quality and quantity. The use of aerators as an effort to improve the quality and quantity of harvest used by pond farmers today generally still uses a manual system, where the operation of the aerator is still based on experience, not from the quality of dissolved oxygen in the pond needed by fish or shrimp in the pond. In this study, the application of an aerator to improve the quality of dissolved oxygen both in quality and quantity, is equipped with an IoT (*Internet of things*) method that can instruct the aerator to operate as desired using a *smartphone*. The components used in this tool consist of solar cell panels as renewable power plants, Aerator Pumps, and ESP8266 WiFi. In this data collection activity, in fluctuating weather conditions. Especially during rainy conditions, data retrieval is paused because test conditions do not allow it to produce a current data reading of 0 amperes. From the logger data recording, it can be seen that the highest current value that can be absorbed through solar panels is 2.40 Amperes obtained on day 3 of testing

INTRODUCTION

Shrimp is one of Indonesia's mainstay animals exported from the fishery sector which needs to be improved both in terms of quality and quantity. With the increasing demand for shrimp exports that are getting higher, efforts to increase shrimp production as an export commodity continue to increase, can be seen through intensification of cultivation and by opening up potential areas outside Java Island. The demand for shrimp from tahun to year is increasing. Anticipating the development of shrimp farming both intensively and extensively has the same risks, especially regarding death. The low quality of pond water can be a driver of the development of pathogenic diseases that cause the death of shrimp. As an effort to improve water quality, it can be done by increasing the level of oxygen dissolved in the water using a device in the form of an aerator. (Wicaksono, 2021), (Efendi, 2018).

The need for air in fish-keeping ponds is vital for the survival of the fish that are kept. Some of the ponds that have been developed do not have sufficient air supply, such as keeping fish in tarpaulins or in aquariums. Some of the problems that arise in fish farming are the survival of the fish when the number of fish increases or the fish increase in size. Lack of air can cause fish to become stressed, easily infected with disease, stunted growth and even cause death. (Novianto, Supriyadi, Adji, & Faisal, 2022). Increasing or growing fish causes the need for air in the water to increase. The solution to supplying air in the pond is to use an aerator. Dissolved oxygen is essential for respiration and is one of the main components in fish metabolism (Rusdi and Syaharuddin, 2010). Aerators that are commonly used generally use electricity directly from PLN or diesel fuel. The consequences of using this energy raises costs that are quite influential on the profits of fish farming. (Novianto et al., 2022)

Currently, the oxygen-producing equipment used by pond farmers in general still uses a pinwheel with a manual work system, where to operate the pinwheel still comes from experience and estimates only, not based on the quality of dissolved oxygen needed by the shrimp in the pond. (Nugraha & Hasan, 2019). So the efforts made so that shrimp get good quality of dissolved oxygen based on the quality and quantity, the researchers made a design and build an aerator control equipped with an IoT (*Internet of things*) method that can control the aerator to operate as desired using a *smartphone*. (Nandika & Gunoto, 2018), (Sutikno & Thalmann, 2022), (Al-Ghaili, Kasim, Othman, & Hashim, 2020).

LITERATURE REVIEW

The Internet of Things (IoT) or also popularly known as the Internet of Everything or the Industrial Internet, is a paradigm of technological invention that is imagined to function as a link for interaction through a global network and interconnected devices. It is recognized as the most important field as one of the technologies used and is able to compete for great attention from a wide variety of industries. The truth value of the company can be well realized when each device can interact with each other and integrate with vendor-managed analytics and business systems, inventory systems, and business analysis systems. The monitoring and control system collects data on equipment performance, energy use, and environmental conditions, and allows managers

and automated controllers to continuously track performance at all times. (Efendi, 2018)

In this research the aerators were made to operate using a source of electrical energy produced by solar cell panels as a provider of electrical energy. The benefits obtained by using solar cells can save electricity costs which can hinder entrepreneurs in remote areas, when compared to the use of electrical energy originating from generator engine that requires fossil fuels. (Iqtimal & Devi, 2018). The reason for using solar cells is that solar panels are suitable for application in Indonesia, because Indonesia is a country located on the equator and has a tropical climate. (setyawan imam, 2019), (Haryanto, 2021).

The ZMPT101b voltage sensor is a sensor that is applied to various functions, one of which can be used to monitor the value of the alternating current (AC) voltage found at two points in a circuit. The ZMPT101b sensor can measure electric voltages ranging from 110-250V AC with an active transformer system feature, compatible with Arduino or AVR microcontrollers, and can be directly connected to a 220V PLN power source. (Hudan, Ivan Safril, 2019)

This research also uses a Solar charge controller which functions to maintain energy balance in the battery by adjusting the maximum and minimum voltage of the battery, this tool also serves to provide security for the system, namely: Protection against overcharging in the battery, protection against over discharge by the load, preventing backflow to the solar module. (Hardiansyah, 2019).

METHOD

The first step in the design of the IoT-based aerator, so that the work procedure can be directed, from the preparation of tools and materials, then starting from its assembly to the process of testing and measuring the tool without using weights, as well as using loads, then the result value will be obtained, from the measurement data to be analyzed and discussed so that it becomes a conclusion and suggestion, where the explanation of the description of the flow chart based on the working structure of the tool can be seen in picture below.

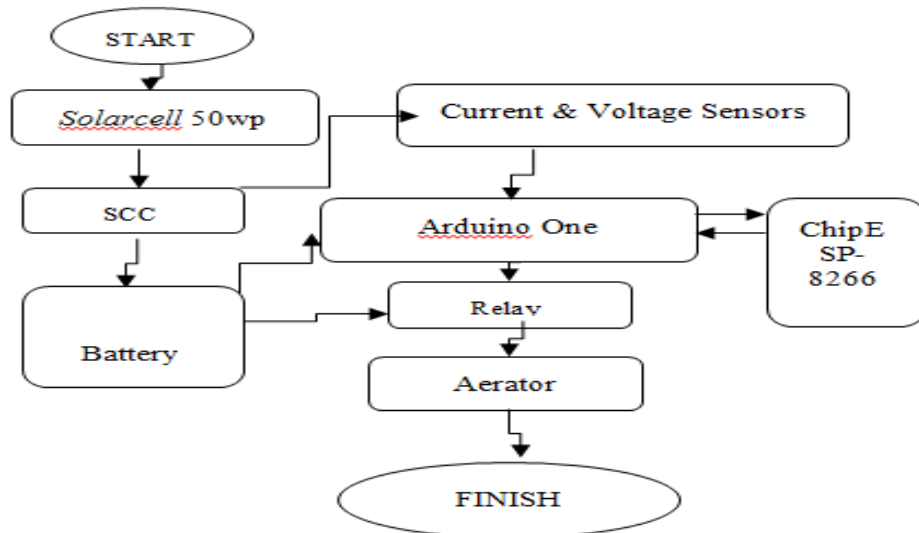





Figure 1. Block Diagram Structure Working Tool

The second process is design and manufacturing process, The process of designing and making this program is divided into two, namely:

a. *Bracketsolar cell* design

The first activity carried out is to make a *solar cell* mount construction. The design of this *bracket* design is to install a *solar cell* at a slope of about 30 degrees with the aim of not collecting rainwater. In addition, the placement of the solar cell with an inclined position is to facilitate the cleaning process from dust on the surface of the *solar cell*. To make this *bracket* using a *frame* in the form of a C canal mild steel construction.

Table 1. Bracket Design

No	Stages	Picture
1	Material measurements	
2	Cutting materials to size	
3	Installation of channel C as brackets on panels	
4	The results of installing solar cell panels on brackets.	

b. Assembly wiring circuit

In this stage, wiring is carried out between each block starting from the solar cell panel to the scc from the scc then continued to the battery then the voltage and current data are connected to the current and voltage sensors. After that the current from the battery will supply arduino uno esp 8266 and aerator through the relay driver circuit, as shown in the following figure.

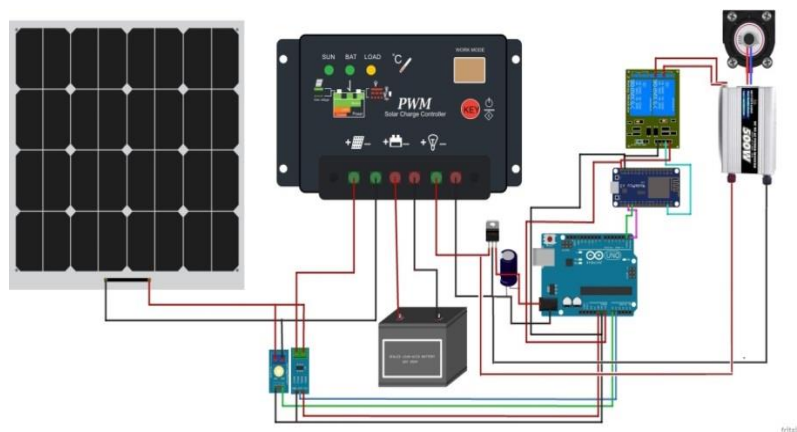

Figure 2. Wiring Circuit

RESULTS AND DICUSSION

Testing of the tools that have been made is carried out all part by part of the system that is built has successfully functioned properly. The initial test was carried out at the performance and function test stage first, after that a field performance test was carried out by applying the tools made, namely the application of Monitoring and Control of Aerators with solar power on shrimp ponds located in North Rawajitu PT Wachyuni Mandira. In this testing activity, it requires measuring instruments in the form of *solar power meters*, internet network connections, and *multimeters*.

Below are the test and measurement steps carried out:

- Testing the input and output voltages of DC-AC inverters.
- Testing the current requirements of aerators
- Taking *solar cell* and aerator test data in the field
 - a. Testing the input and output voltages of DC-AC inverters

This test is carried out to find out whether the dc to ac inverter device used is capable of inverting dc current from a 12 V battery into AC current with a voltage value of 220V.the voltage requirement with an AC current of 220V serves to supply the needs of an aerator pump device as an oxygen generator that will be distributed in shrimp ponds. The following is the testing process carried out.

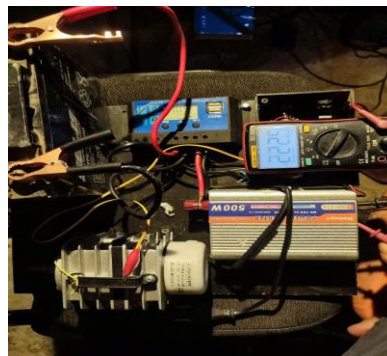

Figure 3. Testing the Input and Output Voltages of DC-AC Inverters

Table 2. DC to AC Inverter Testing

No	Vin (V DC)	Vout (V AC)	Frequency (Hz)
1	13.3	222.9	59.90
2	13.2	223.1	59.91
3	13.2	223.0	59.90
4	13.2	222.6	59.90

b. Testing the Current Needs of Aerators

Testing the current needs of this aerator pump aims to find out the electrical power needs that will be used to activate the aerator. This testing step is very important as a balance between the supply produced by solar cell panels and *energy* consumption by the aerator load. The value of these test

results can be monitored through readings on the application when the aerator pump is activated. The following is a table of test results obtained.

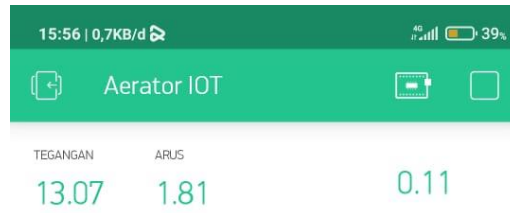

Figure 4. Monitoring When the Aerator Pump is Activated

Table 3. Test Results Via Readings on Applications When the Pump *is on*

No	In	I	P (VA)
1	222.9	0.11	24.52
2	223.1	0.12	26.77
3	223.0	0.11	24.53
4	222.6	0.13	28.94
P(VA) rate-rate			26.19

c. Taking solar cell test data in the field

In this testing step, it is a core part of the data retrieval stage carried out, namely the implementation of tools designed directly on the test media. The test media used is in the form of a shrimp pond located in North Rawajitu PT Wachyuni Mandira. Data processing in this discussion is further divided into daily groupings, to facilitate data analysis and conclusions in relation to natural factors such as weather which greatly determines the test results.

1. First day testing

This test was carried out on June 10, 2021 with a picture of sunny weather conditions in the morning, cloudy during the day, and hot again in the afternoon. Testing starts from 09.00 am to 16.00 pm. The following is the result of the test table carried out.

Table 4. First Day Data Test Results

Hit	In	I	P	Wh
09:00:00	12.26	1.86	22.7519	5.6880
09:15:00	12.66	2.39	30.2382	7.5596
09:30:00	12.77	2.15	27.4054	6.8513
09:45:00	0.00	0.00	0.0000	0.0000
10:00:00	0.00	0.00	0.0000	0.0000
10:15:00	0.00	0.00	0.0000	0.0000
10:30:00	0.00	0.00	0.0000	0.0000
10:45:00	0.00	0.00	0.0000	0.0000
11:00:00	0.00	0.00	0.0000	0.0000
11:15:00	0.00	0.00	0.0000	0.0000
11:30:00	0.00	0.00	0.0000	0.0000
11:45:00	11.96	0.00	0.0000	0.0000
12:00:00	12.22	0.00	0.0000	0.0000
12:15:00	12.19	0.00	0.0000	0.0000
12:30:00	12.73	2.21	28.1394	7.0349
12:45:00	12.58	1.52	19.0776	4.7694
13:00:00	12.77	1.77	22.5527	5.6382
13:15:00	12.72	1.57	20.0005	5.0001
13:30:00	12.92	2.38	30.6948	7.6737
13:45:00	12.85	1.74	22.4093	5.6023
14:00:00	12.41	0.63	7.8475	1.9619
14:15:00	12.69	1.34	16.9813	4.2453
14:30:00	12.68	1.45	18.4172	4.6043
14:45:00	12.99	1.53	19.9421	4.9855
15:00:00	12.51	1.30	16.2226	4.0556
15:15:00	12.08	0.77	9.2956	2.3239
15:30:00	12.05	0.73	8.8044	2.2011
15:45:00	12.64	0.33	4.1315	1.0329
16:00:00	12.46	0.01	0.1082	0.0270

On this first day's *datalogger* recording , there was some data that was not recorded. This condition is caused by the disconnection of the internet network that occurred in the first test results. The test graph is shown in the following image.

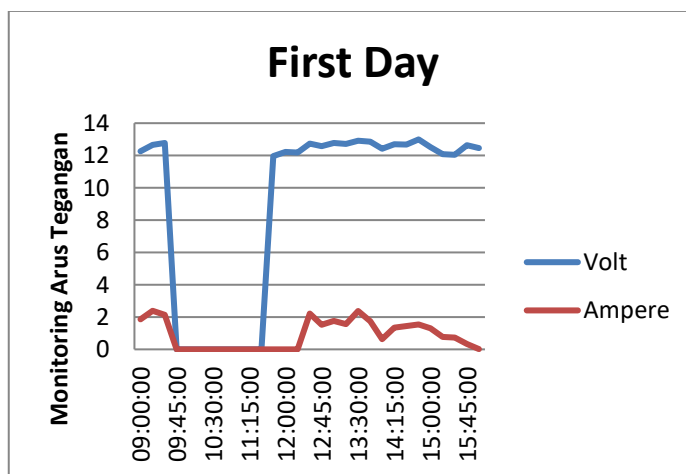

Figure 5. First Day *Datalogger*

From the results of the *picture plot* above, which *g* is a representation of table 3.3 above, it can be seen that the voltage value reading is in the range between 12-12.92 V the highest current reading at 2.39A. in data retrieval on this first day the data *logger* paused between 09:45 and 11:30. This is because the selected internet network connection comes from an internet provider provider that is not supportive of the test area. In the next day's test, a more stable operator selection was replaced so that the availability of data access was not interrupted

2. Second day of testing

This test was carried out on June 11, 2021 with an overview of cloudy weather conditions in the morning, hot during the day, and cloudy again in the afternoon. The following is the result of the test table performed. The following table shows the results of the second day of testing.

On the second day of datalogger recording, there was data that could not be recorded properly. This condition was caused by the rain that occurred at the test site. The test graph is shown in the image below.

From the results of the plot of Figure 7 on the second day which is a representation of the table above, we can see that the results of voltage readings are in the range between 11.65-12.06 V, the highest current reading is at 1.98 A. In data collection on the second day, the data logger was not recorded between 14:45 to 16:00. this is because it rained in the test area so, it could not collect data because the test equipment had not been equipped with a protective box from the weather.

Table 5. Second Day Data Test Results

Pukul	V	I	P	Wh
09:00:00	11.98	0.33	3.9770	0.9942
09:15:00	12.06	0.35	4.1925	1.0481
09:30:00	11.90	0.31	3.6420	0.9105
09:45:00	11.88	0.23	2.7142	0.6786
10:00:00	11.72	0.24	2.8033	0.7008
10:15:00	11.71	0.38	4.4377	1.1094
10:30:00	11.75	0.73	8.5661	2.1415
10:45:00	11.75	0.74	8.7085	2.1771
11:00:00	11.76	0.82	9.6681	2.4170
11:15:00	11.89	1.18	14.0794	3.5199
11:30:00	12.05	1.98	23.8464	5.9616
11:45:00	11.80	1.98	23.3412	5.8353
12:00:00	11.80	0.51	5.9640	1.4910
12:15:00	11.75	0.36	4.2467	1.0617
12:30:00	11.73	0.43	5.0080	1.2520
12:45:00	11.72	0.49	5.7934	1.4483
13:00:00	11.71	0.44	5.1657	1.2914
13:15:00	11.69	0.47	5.4840	1.3710
13:30:00	11.68	0.41	4.8169	1.2042
13:45:00	11.67	0.31	3.5714	0.8928
14:00:00	11.66	0.11	1.2280	0.3070
14:15:00	11.65	0.03	0.3993	0.0998

14:30:00	11.78	0.03	0.3259	0.0815
14:45:00	0.00	0.00	0.0000	0.0000
15:00:00	0.00	0.00	0.0000	0.0000
15:15:00	0.00	0.00	0.0000	0.0000
15:30:00	0.00	0.00	0.0000	0.0000
15:45:00	0.00	0.00	0.0000	0.0000
16:00:00	0.00	0.00	0.0000	0.0000

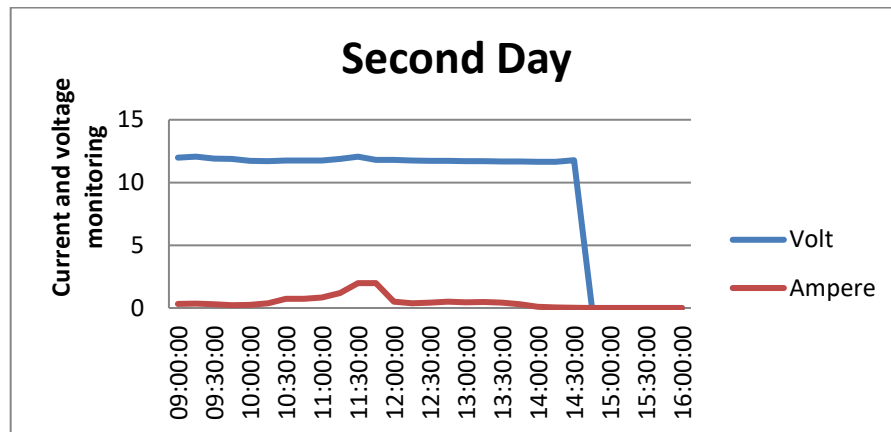

Figure 6. Second Day Datalogger

3. Third day of testing

This test was carried out on June 12, 2021 with an overview of sunny weather conditions in the morning, cloudy during the day to evening. The following are the results of the research carried out.

Table 6. Third Day Data Test Results

No	Hit	In	I	P	Wh
1	09:00:00	11.89	0.4778	5.6791	1.4198
2	09:15:00	12.24	2.2820	27.9367	6.9842
3	09:30:00	12.34	2.4095	29.7307	7.4327
4	09:45:00	12.33	2.4081	29.6872	7.4218
5	10:00:00	12.32	2.2400	27.5893	6.8973
6	10:15:00	12.12	1.9419	23.5279	5.8820
7	10:30:00	12.52	1.8473	23.1286	5.7822
8	10:45:00	12.54	1.6135	20.2333	5.0583
9	11:00:00	12.31	1.0363	12.7520	3.1880
10	11:15:00	12.22	1.0750	13.1401	3.2850
11	11:30:00	11.77	0.4757	5.5990	1.3998
12	11:45:00	11.77	0.4723	5.5590	1.3898
13	12:00:00	11.76	0.4662	5.4832	1.3708
14	12:15:00	11.76	0.4527	5.3223	1.3306
15	12:30:00	11.76	0.5220	6.1391	1.5348
16	12:45:00	11.75	0.5610	6.5939	1.6485
17	13:00:00	11.71	0.3833	4.4888	1.1222
18	13:15:00	11.67	0.3315	3.8693	0.9673
19	13:30:00	11.68	0.5763	6.7300	1.6825
20	13:45:00	11.67	0.6223	7.2599	1.8150

21	14:00:00	11.74	1.2183	14.3004	3.5751
22	14:15:00	11.78	1.3600	16.0145	4.0036
23	14:30:00	11.94	1.7840	21.2990	5.3248
24	14:45:00	11.61	0.3028	3.5173	0.8793
25	15:00:00	11.63	0.6953	8.0899	2.0225
26	15:15:00	11.64	0.7543	8.7772	2.1943
27	15:30:00	11.62	0.7160	8.3166	2.0791
28	15:45:00	11.54	0.0031	0.0358	0.0090
29	16:00:00	11.49	0.0000	0.0000	0.0000

In this third *datalogger* recording , all data is recorded due to a good network. The test graph is shown in the following image.

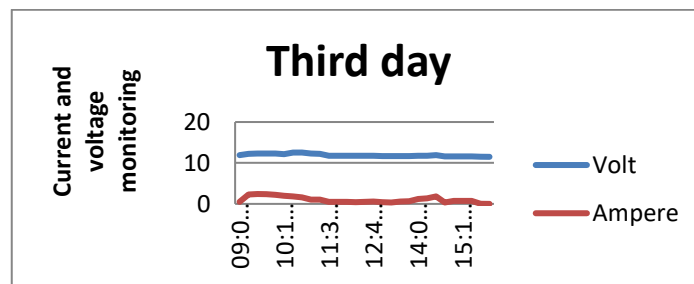

Figure 7. Third Day *Datalogger*

From the results of the *plot* in figure 8 which is a representation of table 6 above, it can be seen that the results of the voltage value readings are in the range between 11.49-12.54 V the highest current reading at 2.4A.

CONCLUSION

The success of monitoring the voltage and current values on solar panels with IoT technology on the supply of wachyuni mandira shrimp pond aerators is largely determined by the stability of the selected internet network provider, on the first day of testing there was a data lag between 09:45 to 11:30 caused by *signal loss*. From the *logger* data recording, it can be seen that the highest current value that can be absorbed through solar panels is 2.40 Amperes obtained on day 3 of testing. In this data collection activity, in fluctuating weather conditions, namely from sunny to cloudy, cloudy to rainy conditions. Especially during rainy conditions, data retrieval is paused because test conditions do not allow this to be seen in data table 4.6 with a reading of 0 amperes. From the aerator test, it was found that the voltage value supplied from the inverter to the aerator terminals was 229V with an inverter frequency of 59.90hz. This condition has an *error* of 1.3% for the voltage value of 220V but the working function of the tool can still work properly.

ADVANCED RESEARCH

Future research is expected to be able to obtain continuous recording of data results even when all climatic conditions are rainy even though it is better if

the tools that are made havewaterproof security with a minimum standard of IP65 so that the tool is still safe to use even in rainy conditions.

ACKNOWLEDGMENT

The research team would like to thank the Palembang Muhammadiyah University campus, especially the service research institute, which has provided assistance so that this research can be completed.

REFERENCES

- Al-Ghaili, A. M., Kasim, H., Othman, M., & Hashim, W. (2020). QR code based authentication method for IoT applications using three security layers. *Telkomnika (Telecommunication Computing Electronics and Control)*, 18(4), 2004–2011. <https://doi.org/10.12928/TELKOMNIKA.V18I4.14748>
- Efendi, Y. (2018). Internet Of Things (Iot) Sistem Pengendalian Lampu Menggunakan Raspberry Pi Berbasis Mobile. *Jurnal Ilmiah Ilmu Komputer*, 4(2), 21–27. <https://doi.org/10.35329/jiik.v4i2.41>
- Hardiansyah, L. J. (2019). *Perancangan Teknis Dan Analisa Ekonomis Pembangkit Listrik Tenaga Surya (PLTS) Terpusat Desa Gutok*.
- Haryanto, T. (2021). Perancangan Energi Terbarukan Solar Panel Untuk Essential Load Dengan Sistem Switch. *Jurnal Teknik Mesin*, 10(1), 43. <https://doi.org/10.22441/jtm.v10i1.4779>
- Hudan, Ivan Safril, R. T. (2019). Rancang Bangun Sistem Monitoring Daya Listrik Pada Kamar Kos Berbasis Internet of Things (Iot). *Jurnal Teknik ELEKTRO*, 08(01), 91–99.
- Iqtimal, Z., & Devi, I. (2018). Aplikasi Sistem Tenaga Surya Sebagai Sumber Tenaga Listrik Pompa Air. *Kitektro*, 3(1), 1–8.
- Nandika, R., & Gunoto, P. (2018). PEMANFAATAN SEL SURYA 50 Wp PADA LAMPU PENERANGAN RUMAH TANGGA DI DAERAH HINTERLAND. *Sigma Teknika*, 1(2), 185. <https://doi.org/10.33373/sigma.v1i2.1516>
- Novianto, S., Supriyadi, Adji, A. A., & Faisal. (2022). Pembuatan Aerator Dengan Menggunakan Tenaga Surya Untuk Pemeliharaan Ikan Pada Kolam Aerator Fabrication Using Solar Power for Fish Farming in a Small Pond Dimension. *Jurnal Abdi Masyarakat Indonesia*, 4(1), 51–56.
- Nugraha, A. R., & Hasan, A. (2019). Kendali Perangkat Elektronik Menggunakan Aplikasi Berbasis Web Menggunakan Arduino. *Jumantaka*, 03(1), 1. Retrieved from <http://jurnal.stmik-dci.ac.id/index.php/jumantaka/article/view/364>
- Sutikno, T., & Thalmann, D. (2022). Insights on the internet of things: past, present, and future directions. *Telkomnika (Telecommunication Computing Electronics and Control)*, 20(6), 1399–1420. <https://doi.org/10.12928/TELKOMNIKA.v20i6.22028>
- Wicaksono, M. S. (2021). *Karakteristik Aerasi dengan Variasi Diameter Nosel*. (September 2019), 2019–2022.